

**F3 PORT AFT TRANSV. FASCIA - REMOVABLE (TABS)  
OUTWARD-FACING SIDE SHOWN**

EXIST. TRANSV. SUPERSTRUCTURE PLATING  
AS ORIENTED WITH INSTALLED FASCIA

- WELD EDGE-EDGE TO FASCIA PLATES (GOUGE WELD?)
- FASTENER TAB 1/4" THICK
- FASTENERS COUNTERSUNK, TAP & SCREW

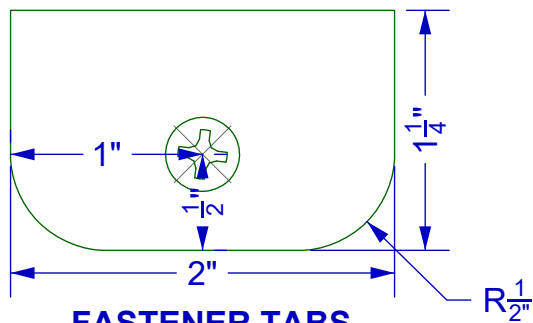

**FASTENER TABS  
FOR F3, F5, F6, F8  
(FULL SCALE)  
14 TOTAL**

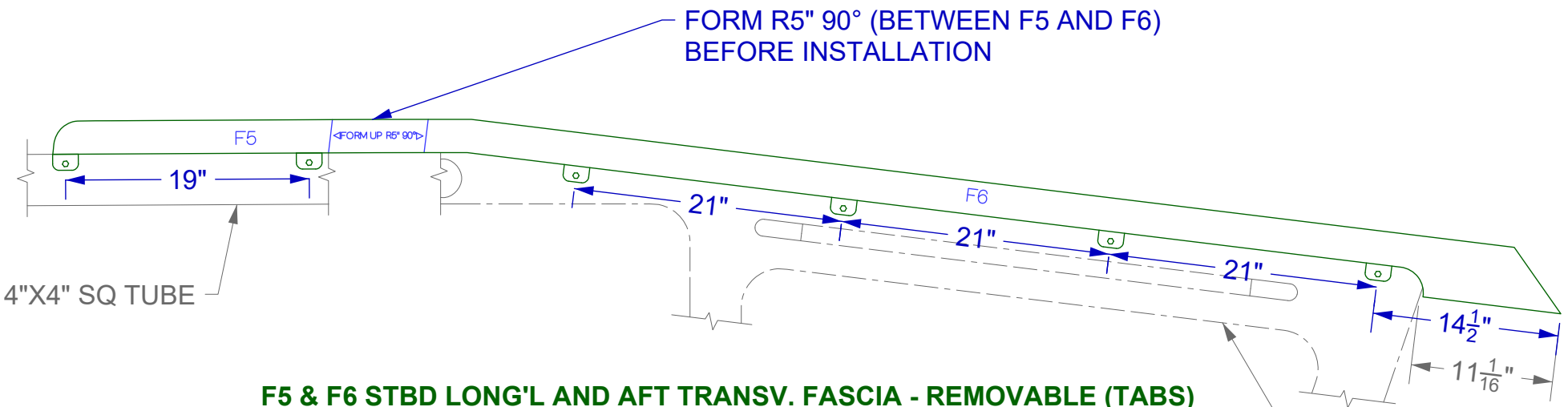

**F5 & F6 STBD LONG'L AND AFT TRANSV. FASCIA - REMOVABLE (TABS)  
OUTWARD-FACING SIDE SHOWN**

EXIST. LONG'L 4"X4" SQ TUBE

EXIST. TRANSV. SUPERSTRUCTURE PLATING

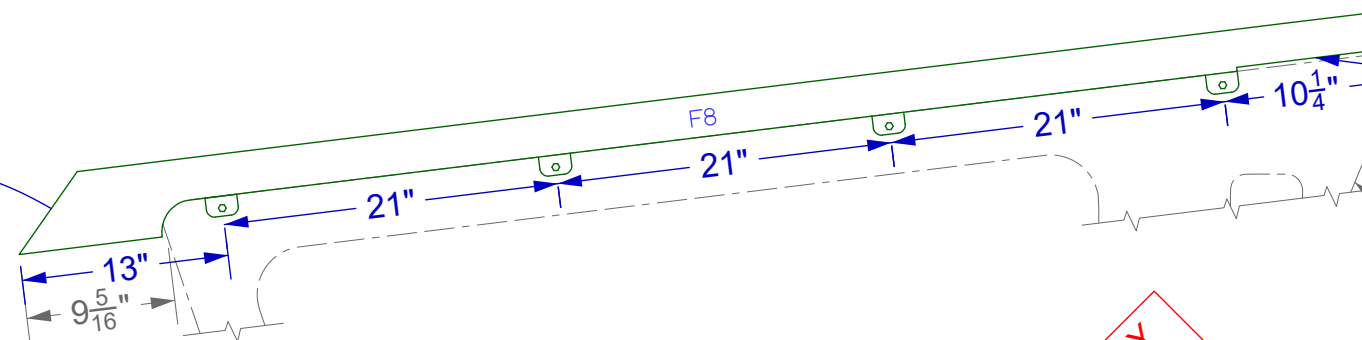
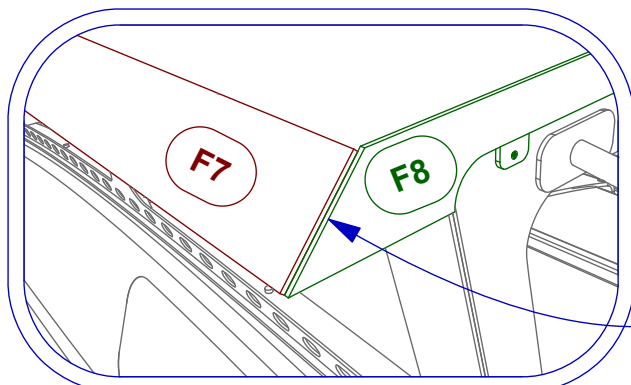

**F8 STBD FWD TRANSV. FASCIA - REMOVABLE (TABS)  
OUTWARD-FACING SIDE SHOWN**

F8 BOTTOM EDGE NOTCHED AT INBD END TO SIT ATOP EXIST. CANOPY PLATE

EXIST. TRANSV. SUPERSTRUCTURE PLATING

TAB SPACING DIMS ARE CTR-CTR

**PRELIMINARY  
NOT FOR  
CONSTRUCTION**

TABBED REMOVABLE FASCIA PLATES (F3, F6, F8) MEET FLANGED REMOVABLE FASCIA PLATES (F2, F7) CORNER-TO-CORNER AT AFT STBD, FWD STBD, & AFT PORT CORNERS OF MAIN SUPERSTRUCTURE

**SOLANDER 38  
SUPERSTRUCTURE FASCIA  
TABBED REMOVABLE PARTS: F3, F5, F6, & F8  
1"=1'-0" OR AS INDICATED / 11" X 17"  
HJN 7 APR 2026  
SHEET 4 OF 6**