

TRIM BUT DO NOT DISCARD PORT OUTBOARD END AT APPROXIMATELY THIS LOCATION -- WILL BE WELDED TO FWD EDGE OF F2 AS REMOVABLE FLANGED COMPONENT

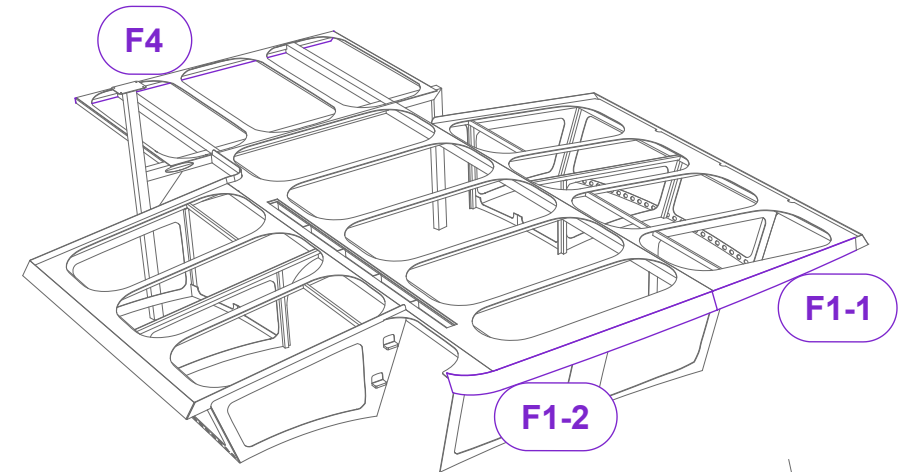

**F1-1 PORT BROW - WELDED**  
SIDE CONTACTING EXIST. CANOPY PLATING SHOWN

1" DELIBERATE GREEN-TRIM TO FIT

1" DELIBERATE GREEN-TRIM TO FIT

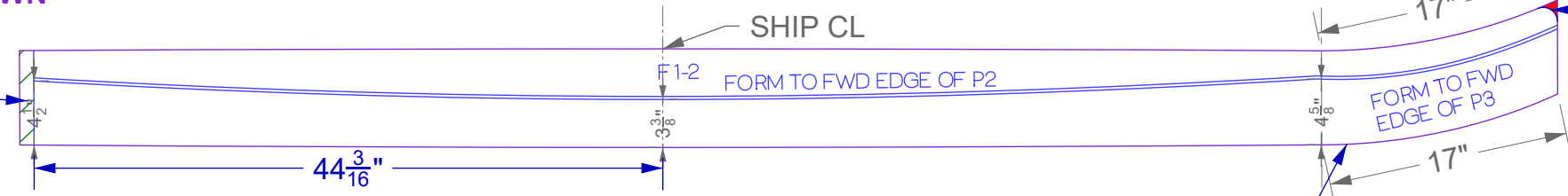

**F1-2 CTR-STBD BROW - WELDED**  
SIDE CONTACTING EXIST. CANOPY PLATING SHOWN

TRIM ~1" RADIUS (PART WILL BE NEAR HANDRAIL)

LONG'L SECTION ANGLES BETWEEN TOP OF CANOPY AND FASCIA AT PROPOSED GUSSET LOCATIONS SEE SHEET 5 FOR LONG'L SECTIONS

STBD OUTBD PORTION FORMED TO TIGHTER CURVE TO MATCH EXISTING CANOPY PLATING -- SEE SHEET 6 FOR FULL SCALE TEMPLATE FORM

**PLANVIEW**  
F1-1 & F1-2 IN PLACE ON FWD SOLAR CANOPY

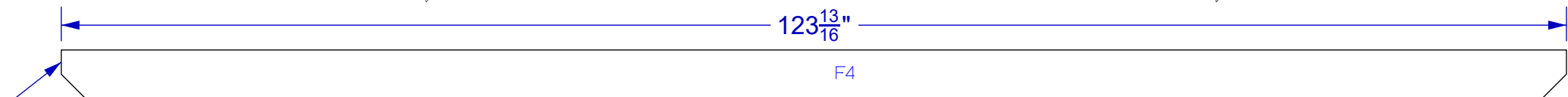
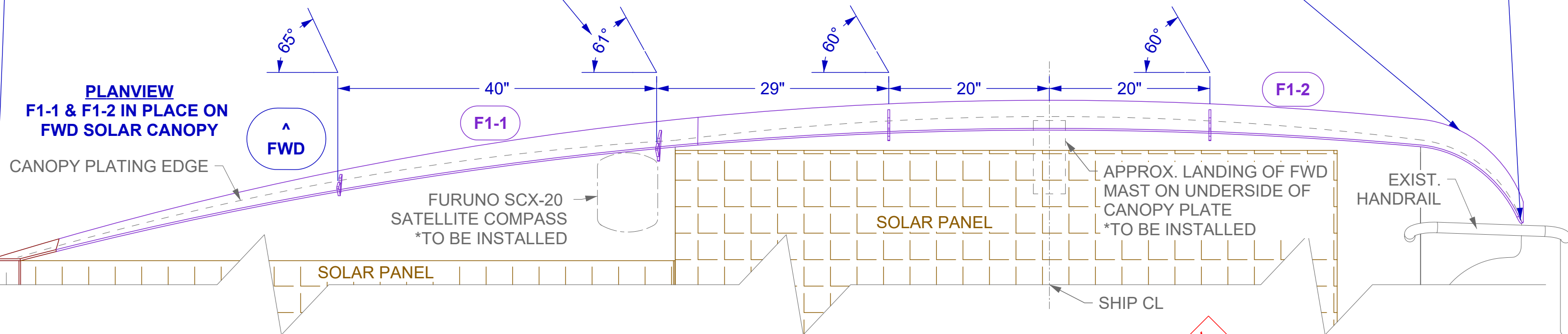

**F4 LOBSTERTAIL AFT FASCIA - WELDED**

P&S EDGES SHOULD BE FLUSH WITH OUTBD FACES OF EXIST. LONG'L 1"X2" TUBES IN LOBSTERTAIL

BTTM EDGE SHOULD BE FLUSH WITH BTTM FACES OF EXIST. LONG'L 4"X4" TUBES IN LOBSTERTAIL

**PRELIMINARY NOT FOR CONSTRUCTION**

**SOLANDER 38**  
SUPERSTRUCTURE FASCIA  
WELDED PARTS: F1-1, F1-2, & F4  
1"=1'-0" / 11" X 17"  
HJN 7 APR 2026  
SHEET 2 OF 6