

**\*THESE ARE THE FASCIA PARTS AS CUT AND MARKED AT TURN POINT DESIGN IN SUMMER 2025.  
 MODIFICATIONS, LOCATIONS, AND FASTENERS FOR INSTALLATION ARE DETAILED ON THE FOLLOWING SHEETS.  
 \*ALL FASCIA PLATE PARTS ARE 1/4" ALUMINUM 5052.  
 \*IF POSSIBLE, DRY FIT CHECK IS RECOMMENDED TO ENSURE PROPER CONTACT AND ALIGNMENT BETWEEN  
 SEPARATE REMOVABLE PARTS.**

LIGHTER BLUE CURVES AND TEXT: "SHARPIE" LAYER OF CUT FILE, MARKED IN SUMMER 2025 AND INCLUDED HERE FOR REFERENCE AND IN CASE OF WEAR

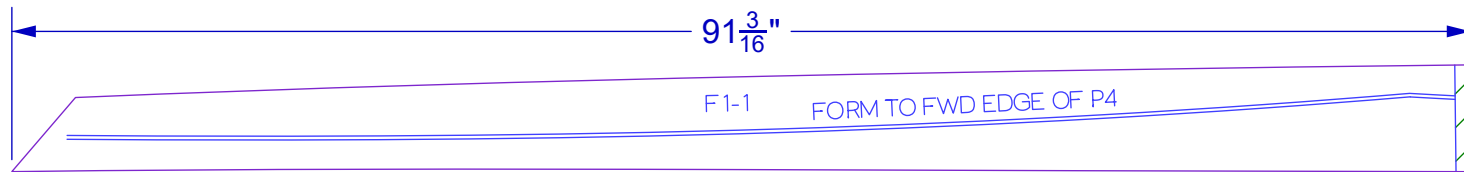

**F1-1 PORT BROW - WELDED**

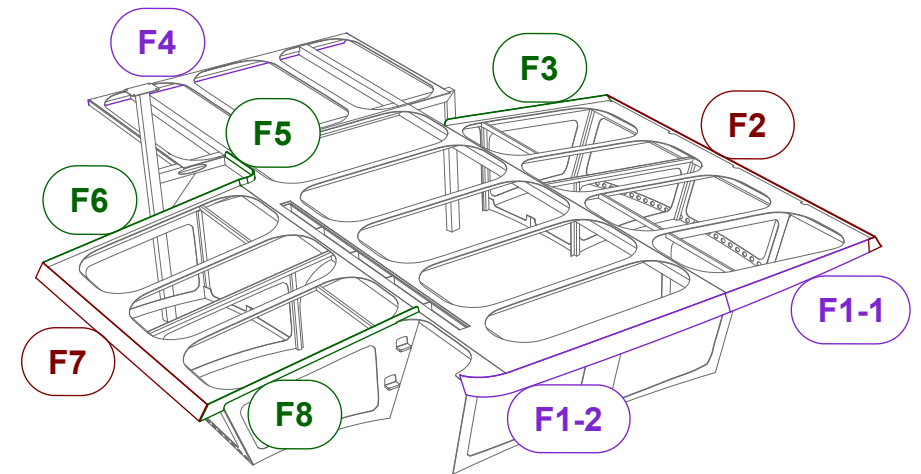
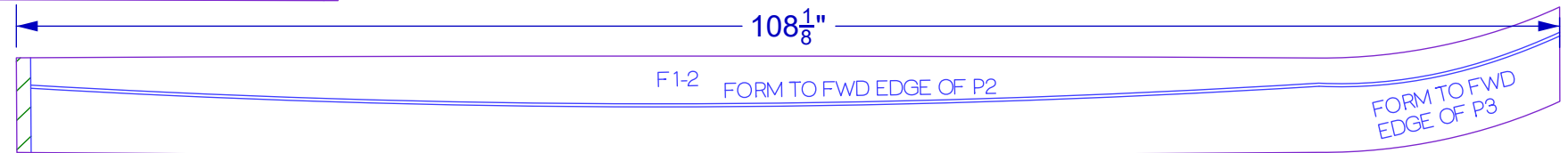

**F1-2 CTR-STBD BROW - WELDED**

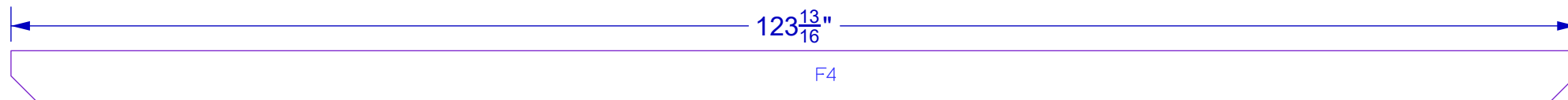

**F4 LOBSTERTAIL AFT FASCIA - WELDED**

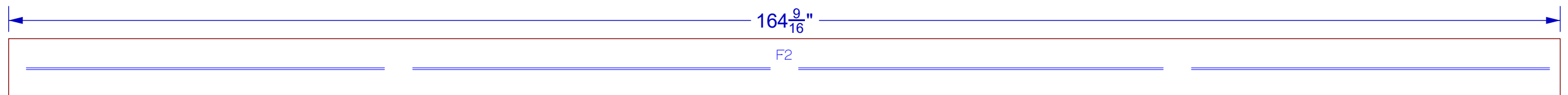

**F2 PORT OUTBOARD LONG'L FASCIA - REMOVABLE (FLANGES)**

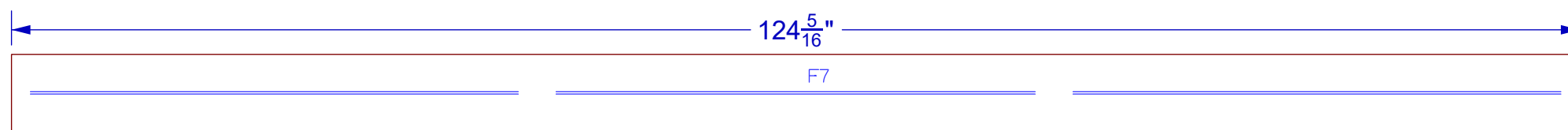

**F7 STBD OUTBOARD LONG'L FASCIA - REMOVABLE (FLANGES)**

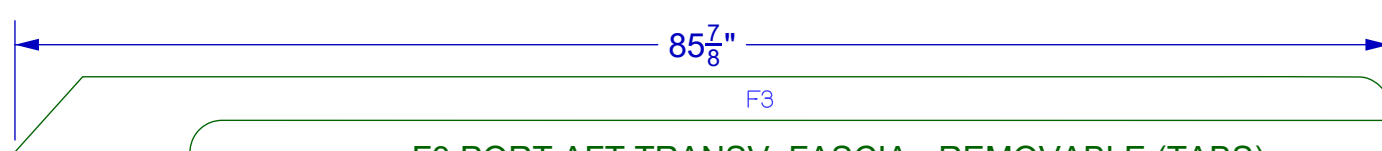

**F3 PORT AFT TRANSV. FASCIA - REMOVABLE (TABS)**

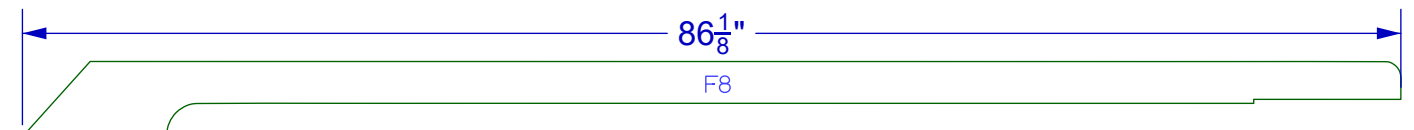

**F8 STBD FWD TRANSV. FASCIA - REMOVABLE (TABS)**

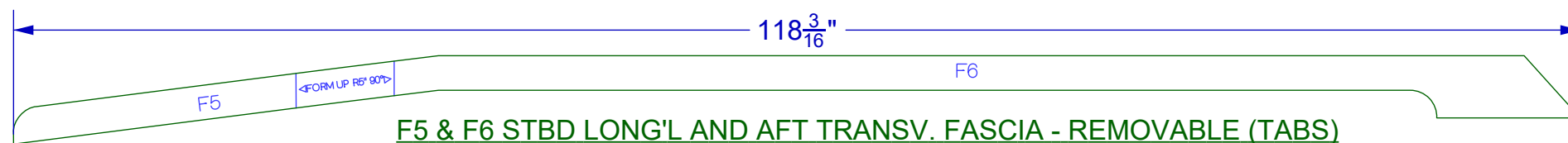

**F5 & F6 STBD LONG'L AND AFT TRANSV. FASCIA - REMOVABLE (TABS)**

**PRELIMINARY  
 NOT FOR  
 CONSTRUCTION**

**SOLANDER 38  
 SUPERSTRUCTURE FASCIA  
 PARTS OVERVIEW  
 1"=1'-0" / 11" X 17"  
 HJN 7 APR 2026  
 SHEET 1 OF 6**